

THE INFORMATION CONTAINED IN THIS DRAWING IS THE SOLE PROPERTY OF ANDERSON POWER PRODUCTS. ANY REPRODUCTION IN PART OR WHOLE WITHOUT THE WRITTEN PERMISSION OF ANDERSON POWER PRODUCTS IS PROHIBITED.

| | |
|------|------------------------|
| BY: | DATE |
| REV. | DESCRIPTION OF CHANGES |

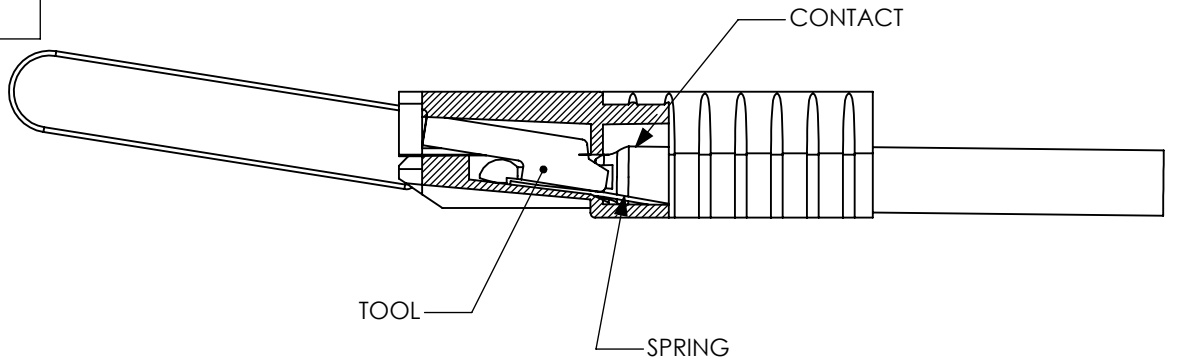

SLIDE TOOL INTO THE MATING END OF THE CONNECTOR, ALONGSIDE THE RIGHT SIDE OF THE CONTACT. PUSH THE TOOL IN UNTIL THE FRONT END IS UNDER THE BARRIER WALL. PUT DOWNWARD PRESSURE ON THE HANDLE, COMPRESSING THE SPRING. WHILE THE SPRING IS COMPRESSED, PULL ON THE CABLE TO EXTRACT THE CONTACT.

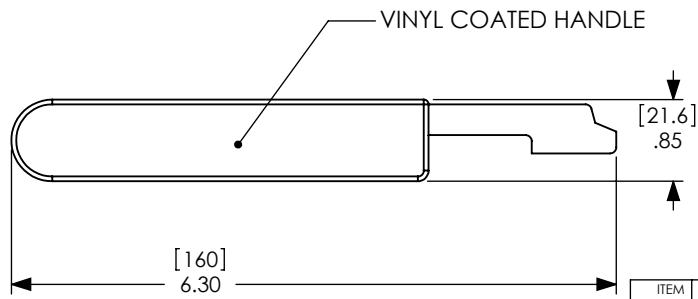
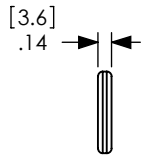
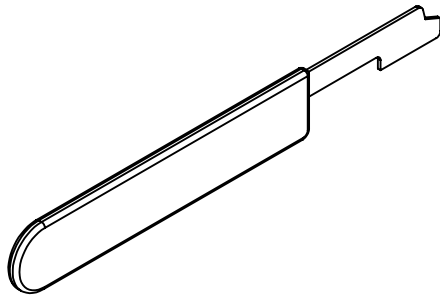

NOTES:
 MATERIAL:
 STAINLESS STEEL STRIP- .042" THK, HEAT TREAT TO Rc40/43
 HANDLE COATING- RED VINYL

| | |
|-------------|---------|
| NEXT ASSY | USED ON |
| APPLICATION | |

| ITEM NO. | PART OR IDENTIFYING NO. | NOMENCLATURE OR DESCRIPTION | MATERIAL SPECIFICATION | QTY REQD |
|---|-------------------------|--|------------------------|--|
| COPYRIGHT 2000 ANDERSON POWER PRODUCTS. ALL RIGHTS RESERVED. UNAUTHORIZED REPRODUCTION HEREBY PROHIBITED. | | | | |
| DIMENSIONS ARE IN INCHES DIMENSIONS IN PARENTHESES [] ARE IN MILLIMETERS | | CAD GENERATED DRAWING, DO NOT MANUALLY UPDATE | | ANDERSON POWER PRODUCTS |
| TOLERANCES ARE: 2PL- ±.02 [±.5] | | APPROVALS | DATE | |
| MATERIALS: SEE NOTES | | DRAWN | CMS 4/25/00 | CATALOG NUMBER 970P1 SBE320/SBX350 EXTRACTION TOOL WITH INSULATED HANDLE |
| FINISH SEE NOTES | | CHECKED | DJD 5/7/00 | |
| DO NOT SCALE DRAWING | | RESP ENG | UFN 5/15/00 | SIZE A |
| | | MFG ENG | CHB 5/15/00 | SPECIFICATION: 114245S1 |
| | | QUAL ENG | RPO 5/8/00 | REV. 0 |
| | | SCALE | NONE | CADFILES/01217 |
| | | SHEET 1 OF 1 | | |