

THE INFORMATION CONTAINED IN THIS DRAWING IS THE SOLE PROPERTY OF ANDERSON POWER PRODUCTS. ANY REPRODUCTION IN PART OR WHOLE WITHOUT THE WRITTEN PERMISSION OF ANDERSON POWER PRODUCTS IS PROHIBITED.

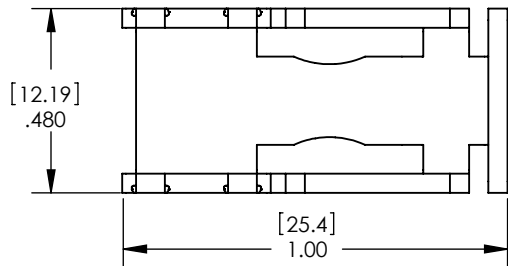
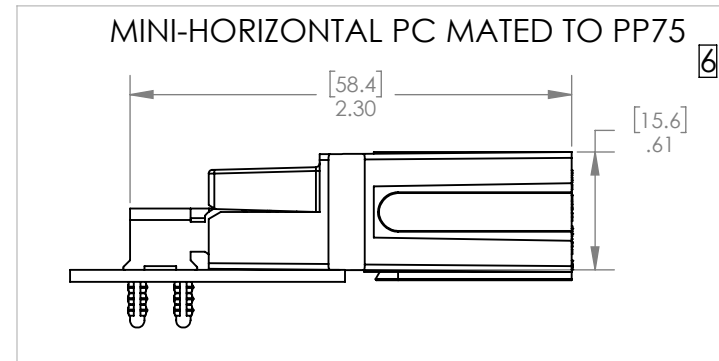
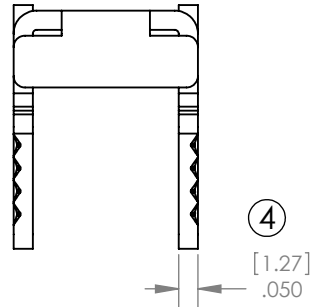
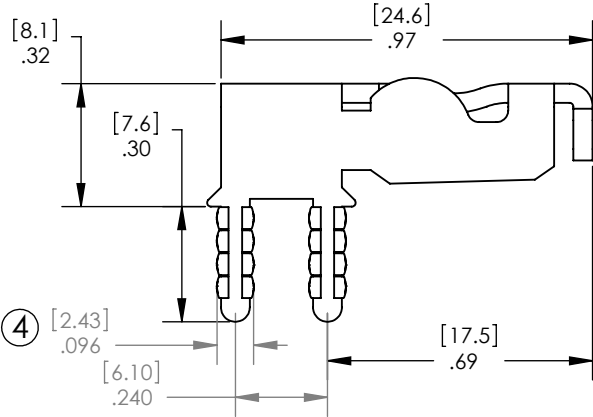
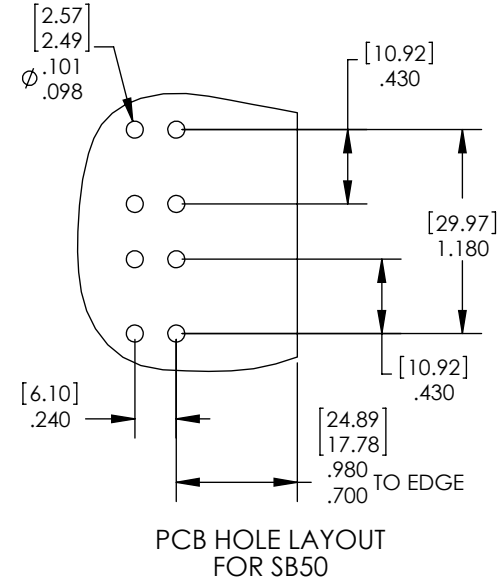
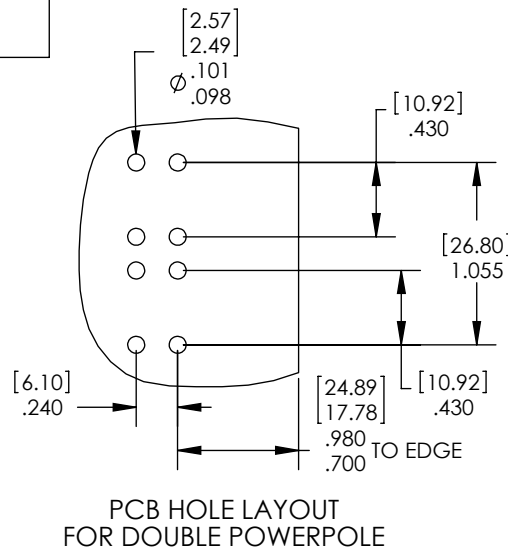
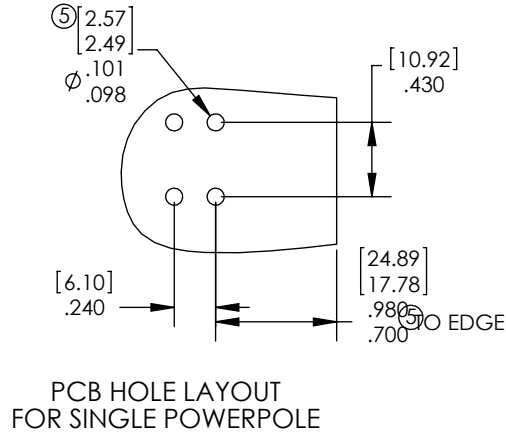

REV.	DESCRIPTION	APPRV	DATE
7	ECN 2022-0069-SB50 CUTOUT 1.155IN TO 1.18IN	AJL	6/30/22
6	ECRN 14878- ADDED VIEW	CMS	4/7/11
5	ECRN 13531	CMS	11/15/02
4	ECRN 13520- ADDED DIMENSIONS	CMS	10/23/02
REVISIONS			

COPYRIGHT 2001 ANDERSON POWER PRODUCTS. ALL RIGHTS RESERVED. UNAUTHORIZED REPRODUCTION HEREBY PROHIBITED.

DIMENSIONS ARE IN INCHES DIMENSIONS IN PARENTHESES [] ARE IN MILLIMETERS		CAD GENERATED DRAWING, DO NOT MANUALLY UPDATE		ANDERSON POWER PRODUCTS	
TOLERANCES ARE: 2PL- ±.02 [±.5]		APPROVALS	DATE		
MATERIAL: COPPER		DRAWN	BL	09-04-01	MINI HORIZONTAL POWER CLAW
FINISH: TIN		CHECKED	DJD	01-10-02	
DO NOT SCALE DRAWING		RESP ENG	UFN	01-15-02	
		MFG ENG	CHB	01-14-02	
		QUAL ENG	RPO	01-10-02	SIZE A
		SCALE NONE		CADFILES/01666	DRAWING NUMBER 114332S2
				SHEET 1 OF 1	REV 7