

THE INFORMATION CONTAINED IN THIS DRAWING IS THE SOLE PROPERTY OF ANDERSON POWER PRODUCTS. ANY REPRODUCTION IN PART OR WHOLE WITHOUT THE WRITTEN PERMISSION OF ANDERSON POWER PRODUCTS IS PROHIBITED.

REV.	DESCRIPTION OF CHANGES	DATE
		BY:
1	ECRN-14849 CLAMP THICKNESS DIMENSION	3-8-11 TWE

8 7 6 5 4 3 2 1

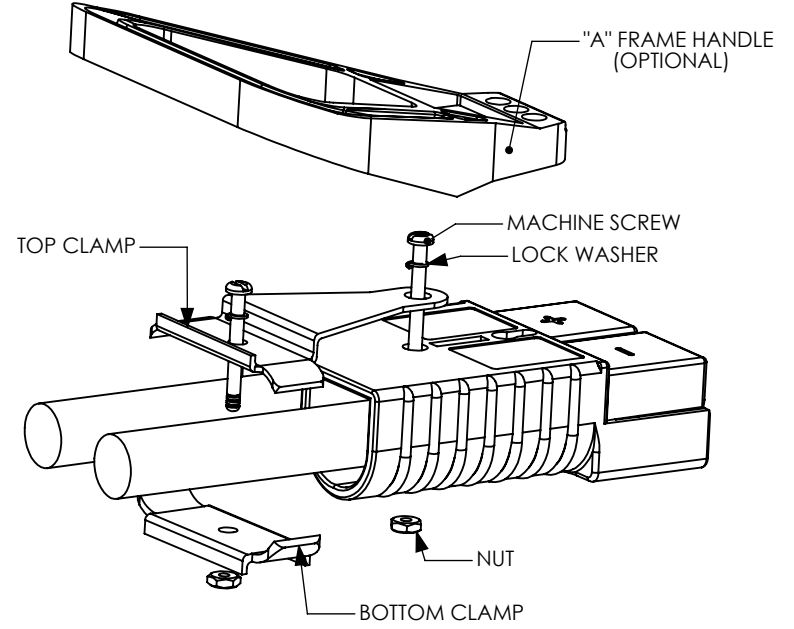
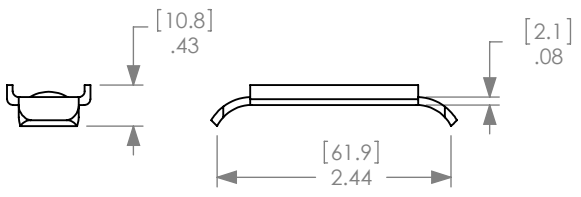
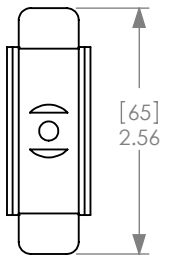
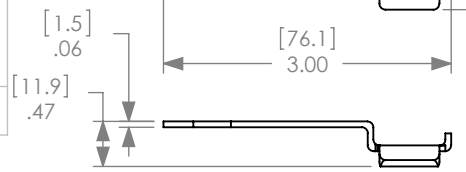
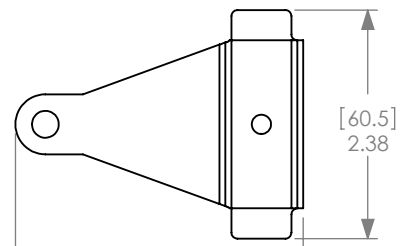

B

A

D

C

B

A

NEXT ASSY	USED ON
APPLICATION	

ITEM NO.	PART OR IDENTIFYING NO.	NOMENCLATURE OR DESCRIPTION	MATERIAL SPECIFICATION	QTY REQD
COPYRIGHT 2000 ANDERSON POWER PRODUCTS. ALL RIGHTS RESERVED. UNAUTHORIZED REPRODUCTION HEREBY PROHIBITED.				
DIMENSIONS ARE IN INCHES DIMENSIONS IN PARENTHESES [] ARE IN MILLIMETERS		CAD GENERATED DRAWING, DO NOT MANUALLY UPDATE	<b>ANDERSON POWER PRODUCTS</b>	
TOLERANCES ARE: 2PL- ±.02 [±.5]		APPROVALS	DATE	
MATERIALS: SEE NOTES		DRAWN	CMS	2/9/00
FINISH		CHECKED	DJD	2/10/00
DO NOT SCALE DRAWING		RESP ENG	UFN	5/8/00
		MFG ENG	CHB	4/28/00
		QUAL ENG	RPO	5/8/00
SIZE	SPECIFICATION:			REV.
A	114231S1			1
SCALE	CADFILES/01193		SHEET 1 OF 1	
NONE				

8 7 6 5 4 3 2 1