

THE INFORMATION CONTAINED IN THIS DRAWING IS THE SOLE PROPERTY OF ANDERSON POWER PRODUCTS. ANY REPRODUCTION IN PART OR WHOLE WITHOUT THE WRITTEN PERMISSION OF ANDERSON POWER PRODUCTS IS PROHIBITED.

Copyright 2020

ANDERSON POWER PRODUCTS RESERVES THE RIGHT TO ALTER PRODUCT TYPES, THEIR TECHNICAL DATA, DIMENSION, STYLE AND ACCESSORIES WITHOUT PRIOR NOTIFICATION.

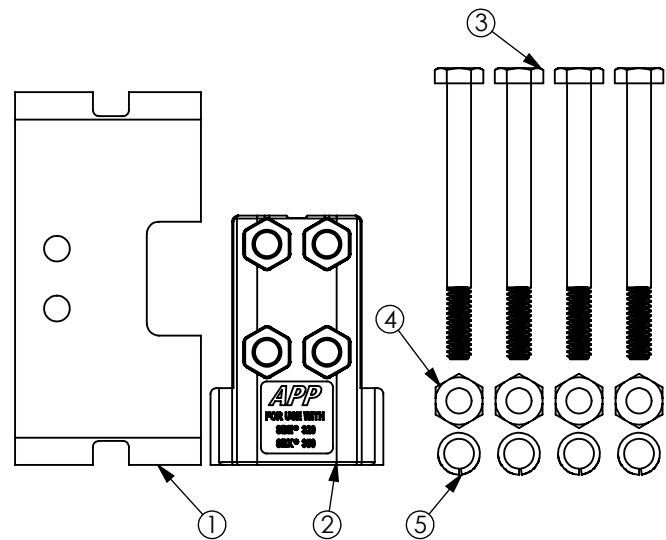

993G5 ASSEMBLED WITH CONNECTORS AND CONTACTS

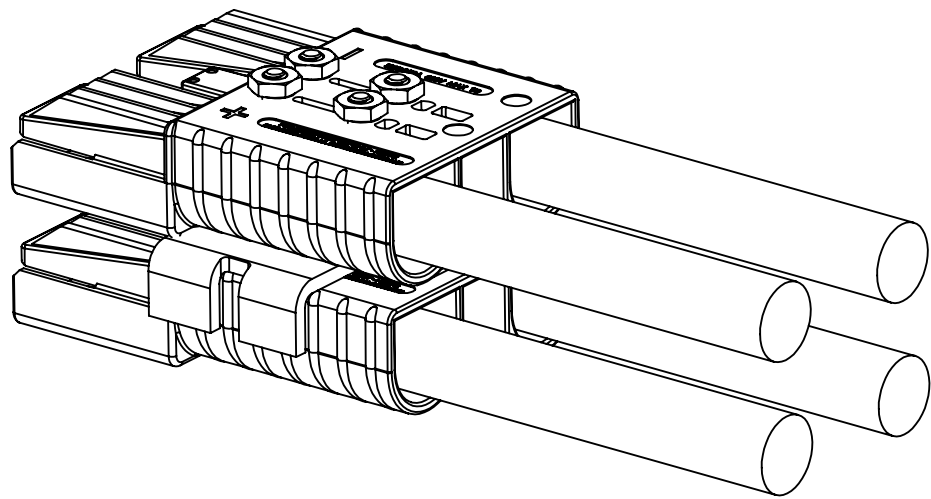

ITEM	QTY.	DESCRIPTION	MATERIALS
1	1	BATTERY SIDE BRACKET- MANUAL RELEASE SBE320/SBX350	STEEL, RED
2	1	SPACER FOR DOUBLE STACKING SBE320/SBX350	PBT, BLACK
3	4	HEX BOLT: 1/4 - 20 x 2-7/8	STEEL, CLEAR Zn
4	4	1/4-20 HEX NUT (THIN)	STEEL, CLEAR Zn
5	4	1/4 INCH LOCKWASHER, STEEL	STEEL, CLEAR Zn

NOTES:

1. KIT DOES NOT INCLUDE HOUSINGS OR CONTACTS
2. FOR USE WITH SBE320 AND SBX350 CONNECTORS ONLY
3. ASSEMBLE PER 1S6827

DIMENSIONS ARE IN:	MM [INCH]	APPROVALS		ANDERSON POWER PRODUCTS
UNLESS OTHERWISE STATED		DRAWN	8/31/2020	
TOLERANCES:		CMS		TITLE CAT. NO. 993G5: MANUAL RELEASE KIT FOR DOUBLE STACKING SBE320/SBX350-BAT
DECIMALS (INCH)	DECIMALS (MM) ANGLES	CHECKED	12/4/2020	
.XX ±.02	.X ±.5 ±2°	CPD		
SURFACE FINISH:		PM APPRV	12/8/2020	
MACHINED	3.2µ [128µin]	CD		
MOLDED	1.6µ [64µin]	QC APPRV	12/9/2020	
MATERIAL:		UFN		
SEE TABLE		ENG APPRV	12/8/2020	
FINISH:		JYL		
3rd ANGLE PROJECTION		-CAD GENERATED DRAWING- DO NOT MANUALLY UPDATE DO NOT SCALE		SIZE A DWG NO. 116014S1 REV. 1
				SCALE NONE CADFILE 05554 SHEET 1 OF 2

REV.	DESCRIPTION	APPRV	DATE
1	ECN 2021-0014- ADD VIEW SHT. 2	CMS	3/22/2021
REVISIONS			

THE INFORMATION CONTAINED IN THIS DRAWING IS THE SOLE PROPERTY OF ANDERSON POWER PRODUCTS. ANY REPRODUCTION IN PART OR WHOLE WITHOUT THE WRITTEN PERMISSION OF ANDERSON POWER PRODUCTS IS PROHIBITED.

Copyright 2021

ANDERSON POWER PRODUCTS RESERVES THE RIGHT TO ALTER PRODUCT TYPES, THEIR TECHNICAL DATA, DIMENSION, STYLE AND ACCESSORIES WITHOUT PRIOR NOTIFICATION.

D

D

C

C

B

B

A

A

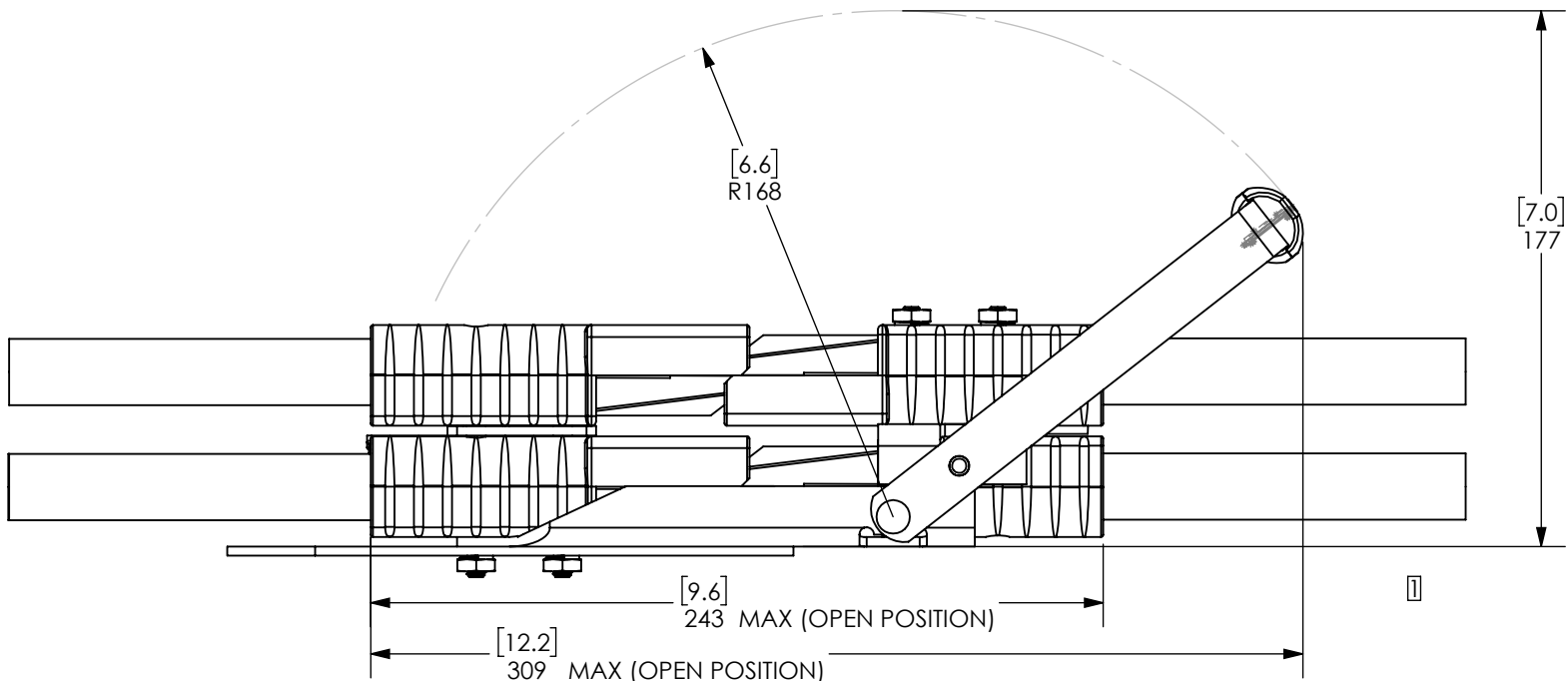

DIMENSIONS ARE IN: MM [INCH]		<i>APPROVALS</i>		ANDERSON POWER PRODUCTS		
UNLESS OTHERWISE STATED		DRAWN	CMS	8/31/2020	TITLE CAT. NO. 993G5: MANUAL RELEASE KIT FOR DOUBLE STACKING SBE320/SBX350-BAT	
TOLERANCES:		CHECKED	CPD	12/4/2020		
DECIMALS (INCH)	DECIMALS (MM)	ANGLES	PM APPRV	CD		12/8/2020
.XX ± .02	.X ± .5	±2°	QC APPRV	UFN		12/9/2020
SURFACE FINISH:		ENG APPRV	JYL	12/8/2020	SIZE	
MACHINED	3.2μ [128μin]				A	
MOLDED	1.6μ [64μin]				DWG NO.	
MATERIAL: SEE TABLE					116014S1	
FINISH:					REV.	
					1	
		-CAD GENERATED DRAWING- DO NOT MANUALLY UPDATE DO NOT SCALE		SCALE	SHEET	
				NONE	2 OF 2	
				CADFILE		
				05554		