

THE INFORMATION CONTAINED IN THIS DRAWING IS THE SOLE PROPERTY OF ANDERSON POWER PRODUCTS. ANY REPRODUCTION IN PART OR WHOLE WITHOUT THE WRITTEN PERMISSION OF ANDERSON POWER PRODUCTS IS PROHIBITED.

Copyright 2015

ANDERSON POWER PRODUCTS RESERVES THE RIGHT TO ALTER PRODUCT TYPES, THEIR TECHNICAL DATA, DIMENSION, STYLE AND ACCESSORIES WITHOUT PRIOR NOTIFICATION.

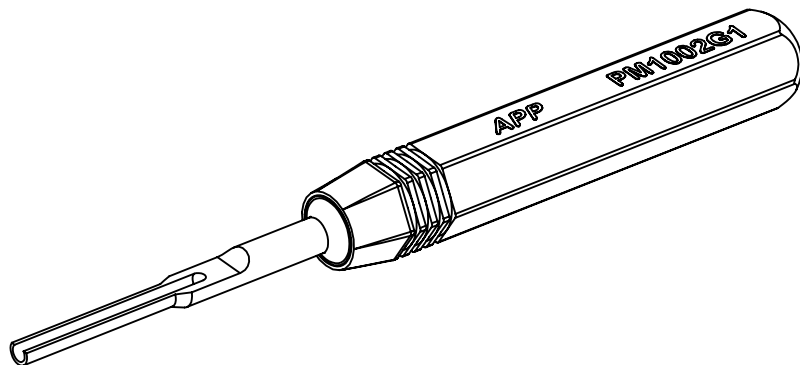

PINS	
PM16P2024S30	
PM16P1620S30	
PM16P2024A30	
PM16P1620A30	
PM16P2024B30	
PM16P1620B30	
PM16P2024C30	
PM16P1620C30	

SOCKETS	
PM16S2024S32	
PM16S1620S32	

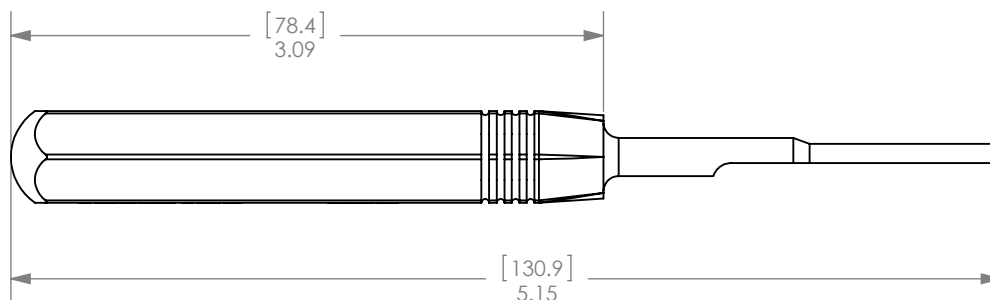

NOTES:

1. MATERIAL: ANODIZED BLACK ALUMINIUM HANDLE, STAINLESS STEEL SHAFT
2. FOR USE ON POWERMOD, SBS75X SERIES, AND SPEC PAK CONNECTORS
3. FOR USE INSTRUCTIONS, SEE POWERMOD, SBS75X, AND SPEC PAK ASSEMBLY INSTRUCTIONS
4. SEE LIST OF CONTACTS TO BE USED WITH THIS TOOL

DIMENSIONS ARE IN:		INCH [MM]		<i>APPROVALS</i>		ANDERSON POWER PRODUCTS	
UNLESS OTHERWISE STATED				DRAWN	BCS	7/7/2015	TITLE POWERMOD CONTACT INSERTION TOOL - CAT. NO. PM1002G1
TOLERANCES:				CHECKED	CMS	7/7/2015	
DECIMALS (INCH)	DECIMALS (MM)	ANGLES		MFG APPRV	CHB	7/7/2015	
.XX ± .02	.X ± .5	±2°		QC APPRV	ASF	7/7/2015	
SURFACE FINISH:				ENG APPRV	CLY	7/7/2015	SIZE
MACHINED		128µin [3.2µ]				A	DWG NO.
MOLDED		64µin [1.6µ]					115451S1
MATERIAL: SEE NOTES							REV.
FINISH:							0
3rd ANGLE PROJECTION				-CAD GENERATED DRAWING- DO NOT MANUALLY UPDATE DO NOT SCALE		SCALE	CADFILE
						NONE	04580
							SHEET
							1 OF 1