

THE INFORMATION CONTAINED IN THIS DRAWING IS THE SOLE PROPERTY OF ANDERSON POWER PRODUCTS. ANY REPRODUCTION IN PART OR WHOLE WITHOUT THE WRITTEN PERMISSION OF ANDERSON POWER PRODUCTS IS PROHIBITED.

Copyright 2004

ANDERSON POWER PRODUCTS RESERVES THE RIGHT TO ALTER PRODUCT TYPES, THEIR TECHNICAL DATA, DIMENSION, STYLE AND ACCESSORIES WITHOUT PRIOR NOTIFICATION.

D

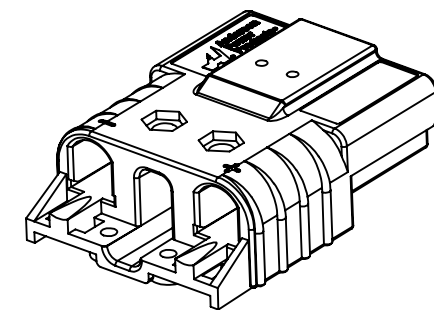
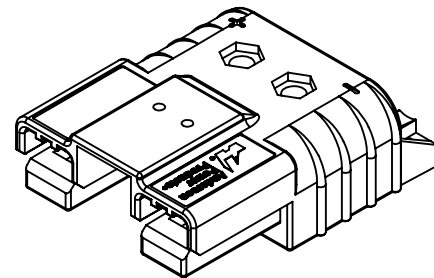
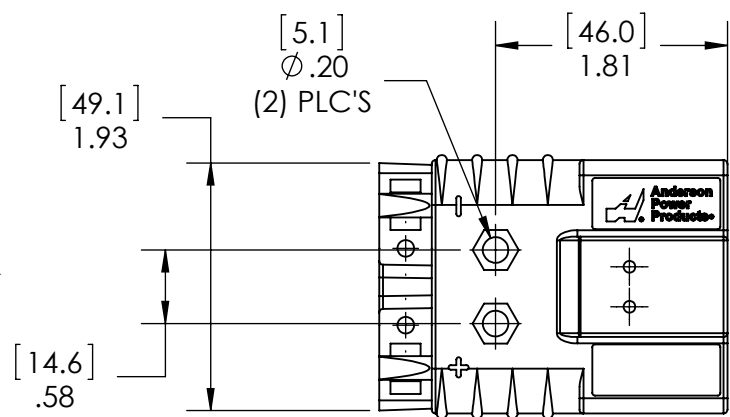

C

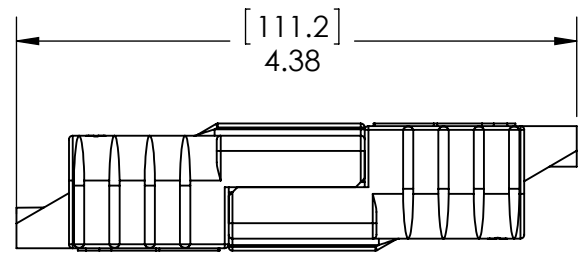
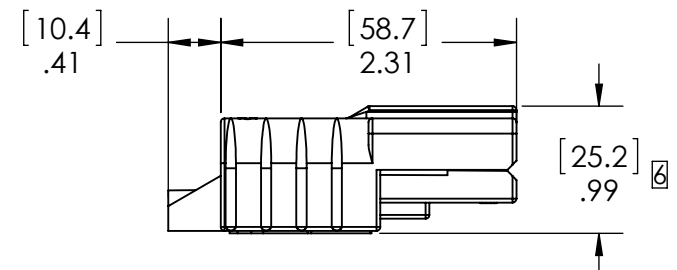

NOTES:

1. SBO 60 SPRING/HOUSING ASSEMBLIES ARE UL RECOGNIZED PER FILE E26226, CSA CERTIFIED PER LR25154.
2. HOUSINGS ARE KEYED TO ONLY ALLOW MATING WITH THE SAME COLOR HOUSING.
3. FOR ASSEMBLY INSTRUCTIONS SEE DOCUMENT 1S6331.
4. MATERIAL:
HOUSINGS - PBT, UL94V0
SPRINGS - STAINLESS STEEL
5. OPTIONAL AUXILIARY POWERPOLE HOUSINGS AND CONTACTS AVAILABLE.

B

A

REV.	DESCRIPTION	APPRV	DATE
7	ECRN-15822A REVISE, REDRAW FOR NEW MOLD	AHR	5/7/2015
6	ECRN-15733	TWE	10/17/2014
5	ECRN-15727	TWE	10/9/2014
4	ECRN-14934 COLOR KEYING ADDED	TWE	7/11/11
3	ECRN-13812 CREATE SEPARATE SBE80 DWG	AMP	4/5/05
2	ECRN-13685 UPDATE LOGO	AMP	3/1/05
REVISIONS			

DIMENSIONS ARE IN:	INCH [MM]	APPROVALS	
UNLESS OTHERWISE STATED		DRAWN	
TOLERANCES:		AMP	4/14/2004
DECIMALS (INCH)	DECIMALS (MM) ANGLES	CHECKED	
.XX ± .02	.X ± .5 ±2°	DJD	4/15/2004
SURFACE FINISH:		MFG APPRV	
MACHINED	128µin [3.2µ]	MAW	4/15/2004
MOLDED	64µin [1.6µ]	QC APPRV	
MATERIAL:		DAM	4/15/2004
SEE NOTES		ENG APPRV	
FINISH:		RPO	4/15/2004
		-CAD GENERATED DRAWING- DO NOT MANUALLY UPDATE DO NOT SCALE	

ANDERSON POWER PRODUCTS

TITLE
SBE 80/SBO60 HOUSING AND SPRING ASSEMBLY OUTLINE DRAWING

SIZE A	DWG NO. 114129S1	REV. 7
SCALE NONE	CADFILE 00999	SHEET 1 OF 2

THE INFORMATION CONTAINED IN THIS DRAWING IS THE SOLE PROPERTY OF ANDERSON POWER PRODUCTS. ANY REPRODUCTION IN PART OR WHOLE WITHOUT THE WRITTEN PERMISSION OF ANDERSON POWER PRODUCTS IS PROHIBITED.

Copyright 2011

ANDERSON POWER PRODUCTS RESERVES THE RIGHT TO ALTER PRODUCT TYPES, THEIR TECHNICAL DATA, DIMENSION, STYLE AND ACCESSORIES WITHOUT PRIOR NOTIFICATION.

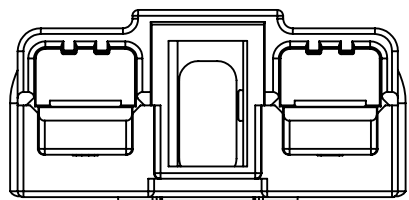

RED KEY

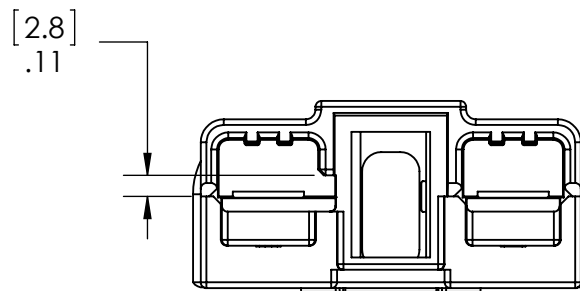

ORANGE KEY

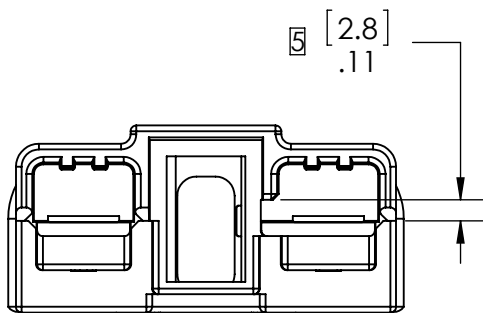

YELLOW KEY

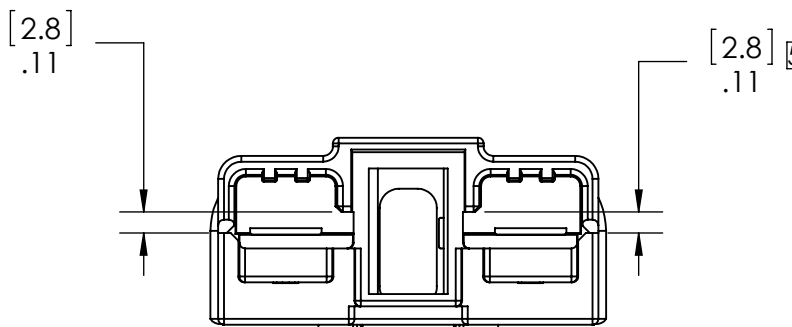

GRAY KEY

DIMENSIONS ARE IN:		INCH [MM]		<i>APPROVALS</i>		ANDERSON POWER PRODUCTS	
UNLESS OTHERWISE STATED				DRAWN	AMP	4/14/04	TITLE SBE 80/SBO 60 HOUSING AND SPRING ASSEMBLY OUTLINE DRAWING
TOLERANCES:				CHECKED	DJD	4/15/04	
SURFACE FINISH:				MFG APPRV	MAW	4/15/04	
MATERIAL:				QC APPRV	DAM	4/15/04	
SEE NOTES				ENG APPRV	RPO	4/15/04	SIZE A
				FINISH:			DWG NO. 114129S1
					-CAD GENERATED DRAWING- DO NOT MANUALLY UPDATE DO NOT SCALE		REV. 6
					SCALE NONE	CADFILE 00999	SHEET 2 OF 2

-	See Sheet1	-	-
REV.	DESCRIPTION	APPRV	DATE
REVISIONS			