

THE INFORMATION CONTAINED IN THIS DRAWING IS THE SOLE PROPERTY OF ANDERSON POWER PRODUCTS. ANY REPRODUCTION IN PART OR WHOLE WITHOUT THE WRITTEN PERMISSION OF ANDERSON POWER PRODUCTS IS PROHIBITED.

Copyright 2010

ANDERSON POWER PRODUCTS RESERVES THE RIGHT TO ALTER PRODUCT TYPES, THEIR TECHNICAL DATA, DIMENSION, STYLE AND ACCESSORIES WITHOUT PRIOR NOTIFICATION.

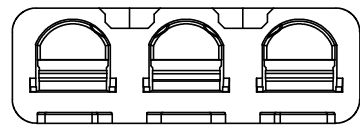
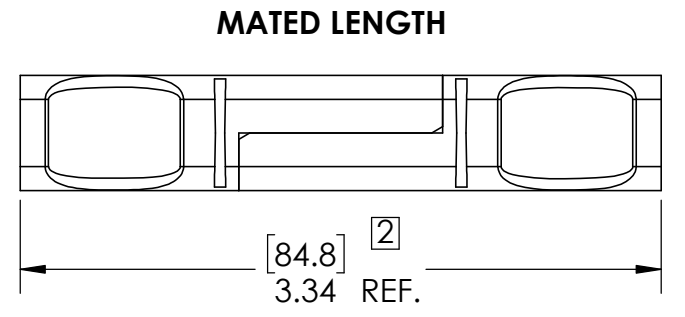
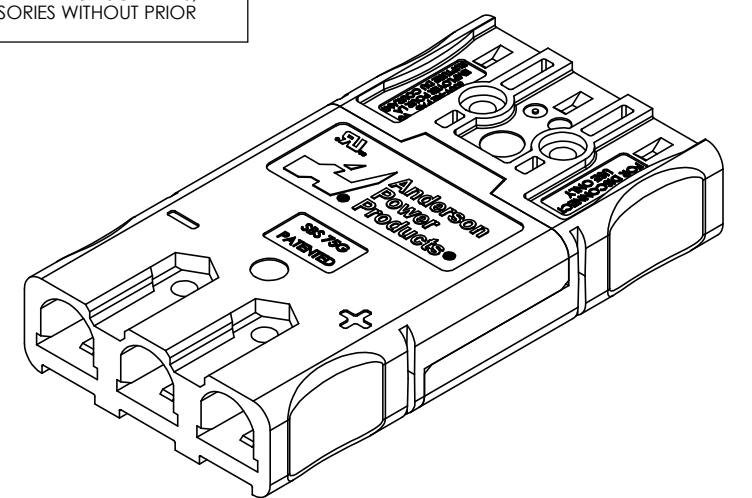
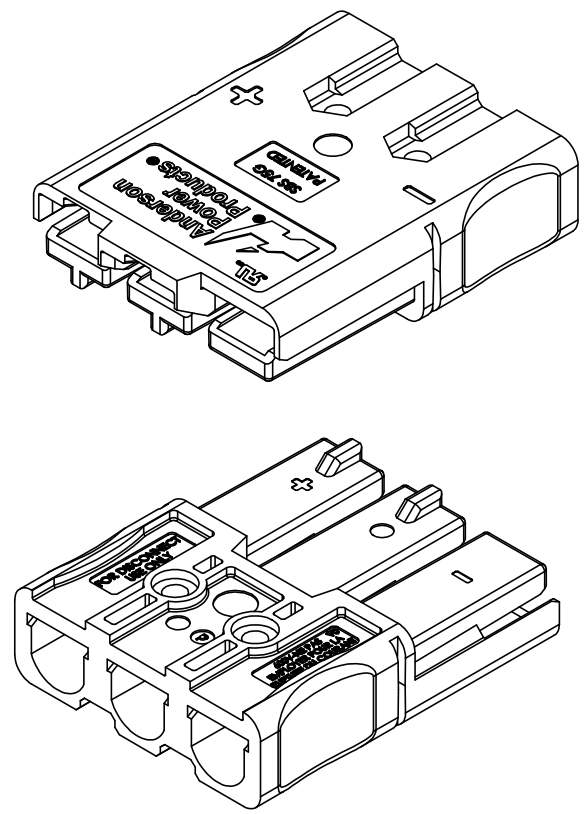
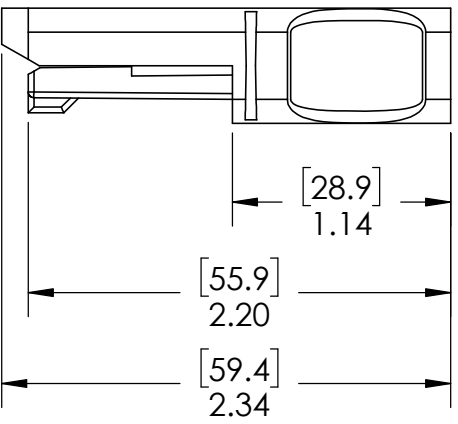
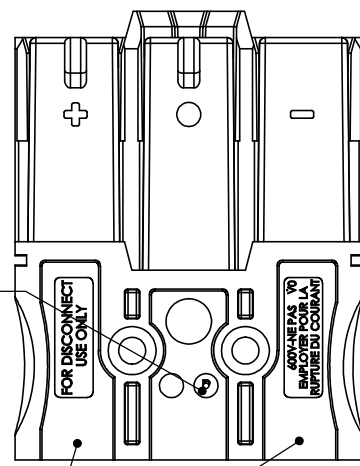
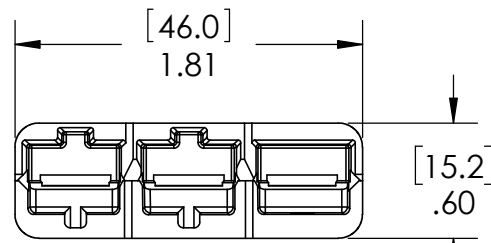
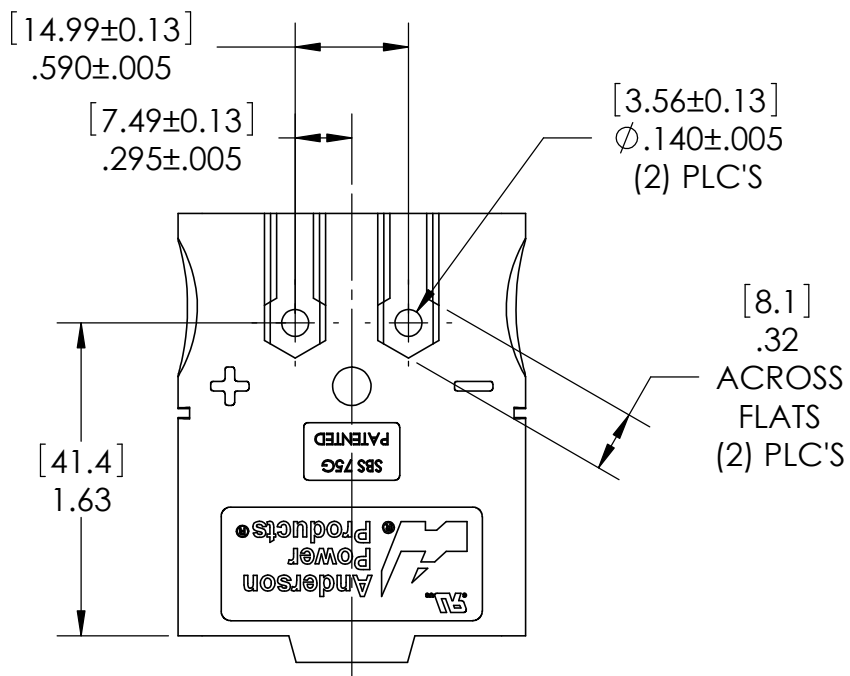
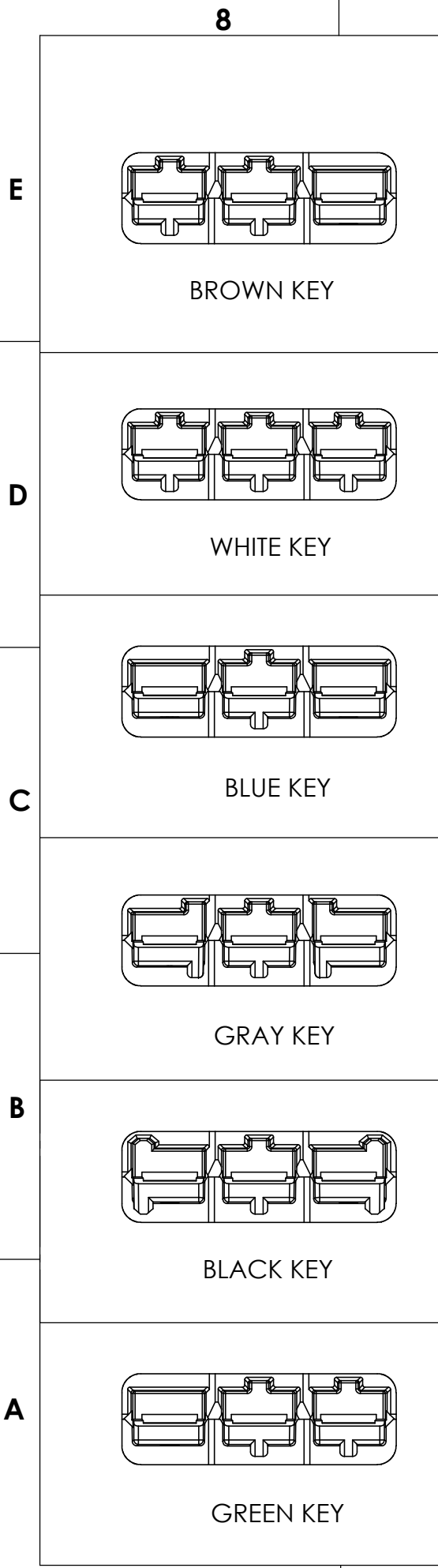

SEE NOTE 4

SEE NOTE 5

- NOTES:
- HOUSING MATERIAL: SEE TABLE
 - SPRING MATERIAL: STAINLESS STEEL
 - CONTACT FACTORY FOR ADDITIONAL COLORS & KEYS
 - "P" MATERIAL ID AND P/N PREFIX INDICATES CHEMICAL RESISTANT HOUSING MANUFACTURING AND AGENCY MARKINGS SHOWN ON THIS SURFACE.
 -

COLOR	APP P/N (SEE NOTE 4)	MATERIAL
BROWN	SBS75GBRN	POLYCARBONATE
WHITE	SBS75GWHT	POLYCARBONATE
BLUE	SBS75GBLU	POLYCARBONATE
GRAY	NOT ASSIGNED	POLYCARBONATE
BLACK	SBS75GBLK	POLYCARBONATE
	PSBS75GBLK	PC + PBT
GREEN	NOT ASSIGNED	POLYCARBONATE

DIMENSIONS ARE IN:	INCH [MM]	APPROVALS	
UNLESS OTHERWISE STATED TOLERANCES:		DRAWN	NTS 6/15/2011
DECIMALS (INCH)	DECIMALS (MM)	CHECKED	LLD 6/16/2011
.XX ±.02	.X ±.5	MFG APPRV	BD 6/16/2011
SURFACE FINISH:		QC APPRV	UFN 6/16/2011
MACHINED	64 [1.6]	ENG APPRV	BD 6/16/2011
MOLDED	32 [0.8]	MATERIAL: SEE NOTES	
FINISH:		MATERIAL: SEE NOTES	

ANDERSON POWER PRODUCTS		
TITLE		
APP KEYING OUTLINE FOR SBS75G THREE POLE CONNECTOR		
SIZE	DWG NO.	REV.
B	B02106S3	1
SCALE	CADFILE	SHEET
NONE	03370	1 OF 1

REV.	DESCRIPTION	APPRV	DATE
2	ECN 2016-0112 - ADDED NOTE 5, REM. MATERIAL I.D.	CPD	12/9/2016
1	ECRN 15159 - ADDED P/N'S TO APP KEYING OUTLINE	TWE	6/4/2012

REVISIONS

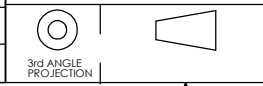

-CAD GENERATED DRAWING- DO NOT MANUALLY UPDATE DO NOT SCALE