

THE INFORMATION CONTAINED IN THIS DRAWING IS THE SOLE PROPERTY OF ANDERSON POWER PRODUCTS. ANY REPRODUCTION IN PART OR WHOLE WITHOUT THE WRITTEN PERMISSION OF ANDERSON POWER PRODUCTS IS PROHIBITED.

Copyright 2006

ANDERSON POWER PRODUCTS RESERVES THE RIGHT TO ALTER PRODUCT TYPES, THEIR TECHNICAL DATA, DIMENSION, STYLE AND ACCESSORIES WITHOUT PRIOR NOTIFICATION.

Part No.	AWG	mm	IN	mm	IN
PM16S2024S32	20/22/24	1.1	.04	2.0	.08
PM16S1620S32	16/18/20	1.7	.07	2.8	.11
PM16S1416S32	14/16	2.1	.08	2.8	.11
PM16S12S32	12	2.6	.10	N/A	N/A

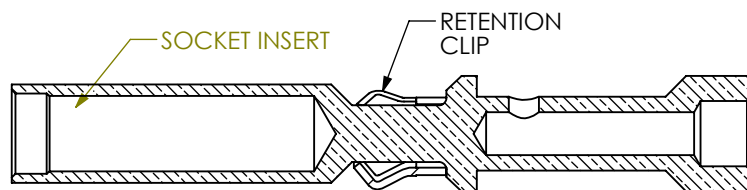
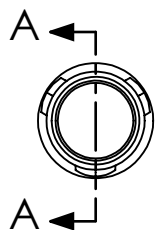
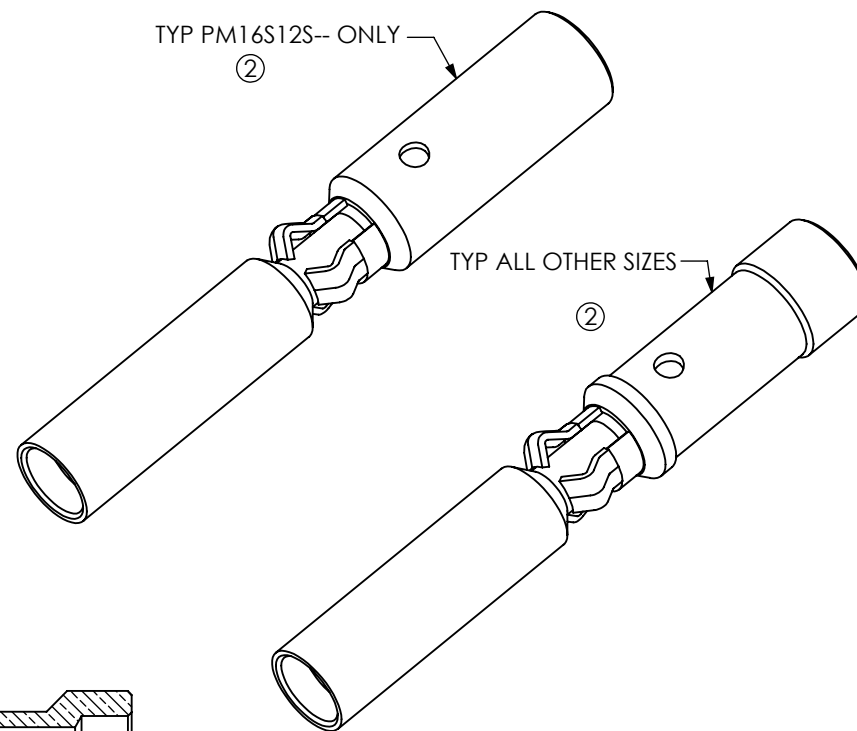

SECTION A-A

NOTES:

- MATERIAL:
CONTACT BODY: BRASS
SOCKET INSERT: BeCu
RETENTION CLIP: STAINLESS STEEL
- FINISH: LEAD FREE
CONTACT BODY- BRIGHT TIN OVER NICKEL
SOCKET INSERT- GOLD OVER NICKEL
- CRIMP CONTACT ONTO WIRE BEFORE INSERTING INTO HOUSING

DIMENSIONS ARE IN:		MM [INCH]	APPROVALS		 ANDERSON POWER PRODUCTS TITLE
UNLESS OTHERWISE STATED			DRAWN	CMS 1/30/06	
TOLERANCES:			CHECKED	DJD 1/31/06	
DECIMALS (INCH)	DECIMALS (MM)	ANGLES	MFG APP	CHB 2/3/06	
.XX ± .02	.X ± .5	± 2°	QC APP	JA 1/30/06	
SURFACE FINISH:			ENG APP	UFN 2/3/06	SIZE
ISO 1302 ✓			MATERIAL: SEE NOTES		DWG NO.
FINISH: SEE NOTES			MATERIAL: SEE NOTES		A/A4
MATERIAL: SEE NOTES			FINISH: SEE NOTES		114646S1
MATERIAL: SEE NOTES			FINISH: SEE NOTES		REV. 3
MATERIAL: SEE NOTES			FINISH: SEE NOTES		SCALE
MATERIAL: SEE NOTES			FINISH: SEE NOTES		NONE
MATERIAL: SEE NOTES			FINISH: SEE NOTES		CADFILE
MATERIAL: SEE NOTES			FINISH: SEE NOTES		02499
MATERIAL: SEE NOTES			FINISH: SEE NOTES		SHEET
MATERIAL: SEE NOTES			FINISH: SEE NOTES		1 OF 1

REV.	DESCRIPTION OF CHANGES	APPROVED	DATE
3	ECRN 15840: REMOVE PART NO'S WITH S30 SUFFIX; REMOVE PLATING COLUMN FROM TABLE; CHANGE NOTE 2 ACCORDINGLY	BCS	7/7/2015
2	ECRN 14485: ADD Ø3.1, ADD ISO VIEW FOR #12 CONTACT	CMS	9/11/09
1	ECRN 14034	CMS	6/19/06

REV.	DESCRIPTION OF CHANGES	APPROVED	DATE
3	ECRN 15840: REMOVE PART NO'S WITH S30 SUFFIX; REMOVE PLATING COLUMN FROM TABLE; CHANGE NOTE 2 ACCORDINGLY	BCS	7/7/2015
2	ECRN 14485: ADD Ø3.1, ADD ISO VIEW FOR #12 CONTACT	CMS	9/11/09
1	ECRN 14034	CMS	6/19/06