

THE INFORMATION CONTAINED IN THIS DRAWING IS THE SOLE PROPERTY OF ANDERSON POWER PRODUCTS. ANY REPRODUCTION IN PART OR WHOLE WITHOUT THE WRITTEN PERMISSION OF ANDERSON POWER PRODUCTS IS PROHIBITED.

Copyright 2010

ANDERSON POWER PRODUCTS RESERVES THE RIGHT TO ALTER PRODUCT TYPES, THEIR TECHNICAL DATA, DIMENSION, STYLE AND ACCESSORIES WITHOUT PRIOR NOTIFICATION.

ITEM NO.	QTY.	DESCRIPTION
1	1	SPEC PAK™ 4 POSITION IN-LINE RECEPTACLE AND SOLAR LATCH ASSEMBLY
2	1	SPEC PAK™ RECEPTACLE POWERPOLE® HOLDER

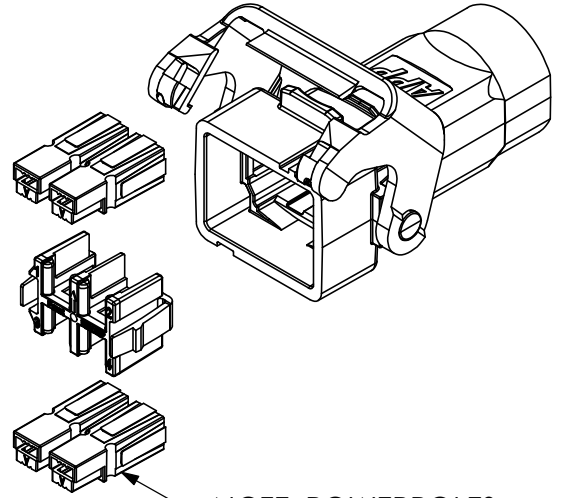
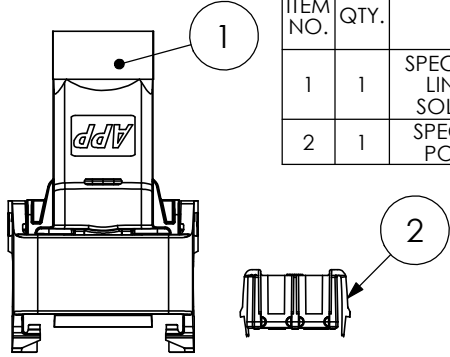

NOTE: POWERPOLES ORDERED SEPARATELY

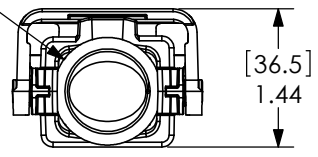
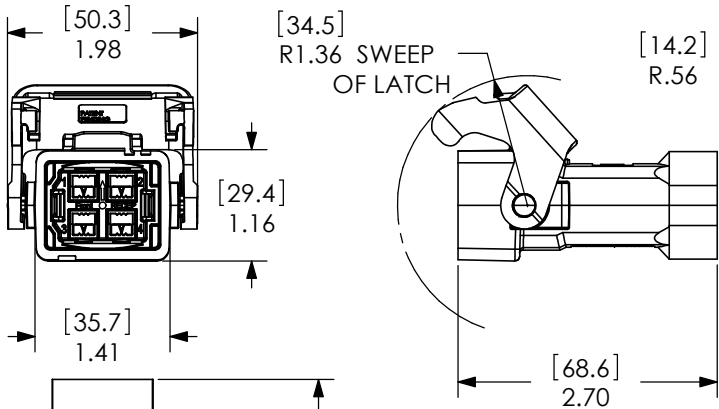

RECEPTACLE MATED LENGTHS

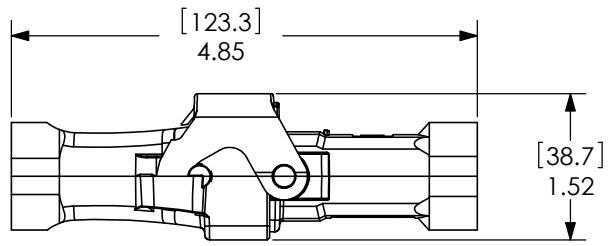
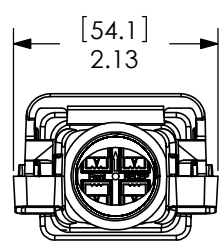

- NOTES:
- MATERIAL:
 A. RECEPTACLE HOUSING- PBT/PC BLEND, BLACK
 B. HOLDER- POLYCARBONATE, BLACK
 C. PANEL GASKET- NBR, BLACK
 REFER TO ASSEMBLY INSTRUCTIONS
 - REFER TO ASSEMBLY INSTRUCTIONS
 - FOR USE WITH PP15/45 POWERPOLE CONTACTS AND HOUSINGS ONLY

DIMENSIONS ARE IN:	INCH [MM]	APPROVALS		 ANDERSON POWER PRODUCTS
UNLESS OTHERWISE STATED		DRAWN	JHN 12/8/2010	
TOLERANCES:		CHECKED	MM 12/8/2010	TITLE SPEC PAK™: PK1-050B04 4-POSITION, PP15/45 IN-LINE RECEPTACLE WITH SOLAR LATCH
DECIMALS (INCH) DECIMALS (MM) ANGLES .XX ±.02 .X ±.5 ±2°		MFG APPRV	CHB 12/8/2010	
SURFACE FINISH:		QC APPRV	HN 12/8/2010	
MATERIAL: SEE NOTES		ENG APPRV	CMS 12/8/2010	SIZE A
FINISH: N/A		-CAD GENERATED DRAWING- DO NOT MANUALLY UPDATE DO NOT SCALE		DWG NO. 114923S1
 3rd ANGLE PROJECTION		SCALE NONE		REV. 0
REVISIONS		CADFILE 03001		SHEET 1 OF 1

REV.	DESCRIPTION	APPRV	DATE