

THE INFORMATION CONTAINED IN THIS DRAWING IS THE SOLE PROPERTY OF ANDERSON POWER PRODUCTS. ANY REPRODUCTION IN PART OR WHOLE WITHOUT THE WRITTEN PERMISSION OF ANDERSON POWER PRODUCTS IS PROHIBITED.

Copyright 2010

ANDERSON POWER PRODUCTS RESERVES THE RIGHT TO ALTER PRODUCT TYPES, THEIR TECHNICAL DATA, DIMENSION, STYLE AND ACCESSORIES WITHOUT PRIOR NOTIFICATION.

PANEL LAYOUT

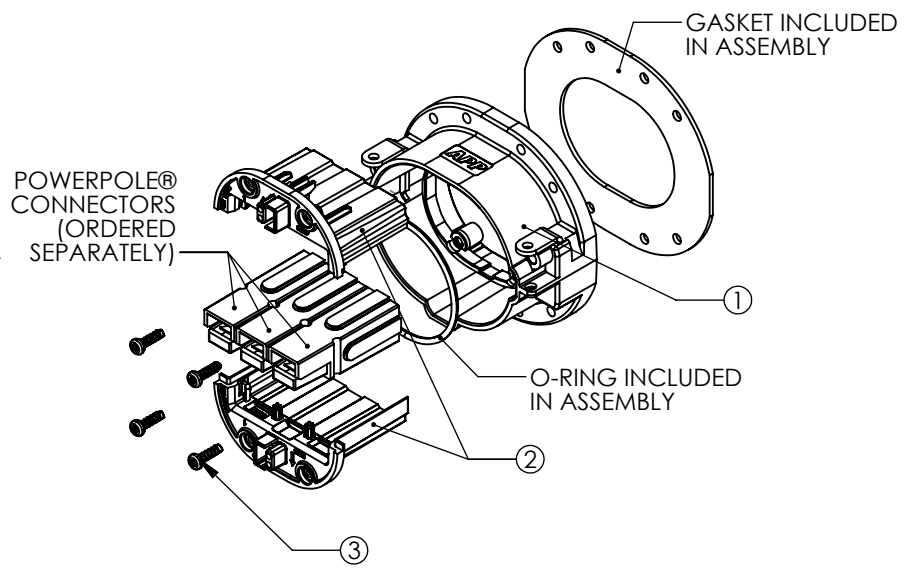
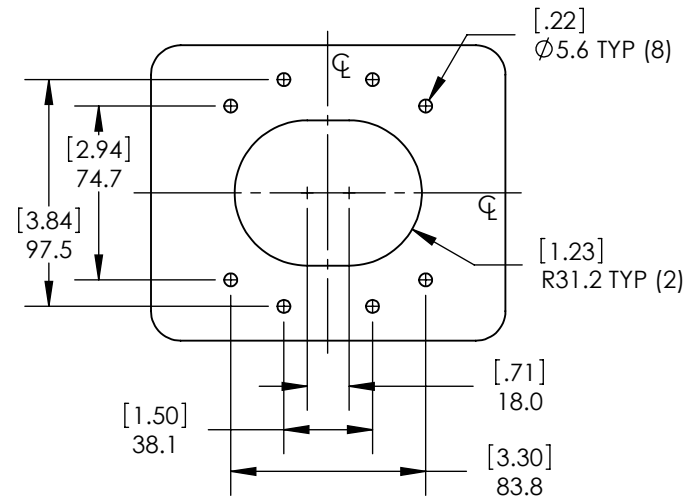

INCLUDED COMPONENTS

ITEM	QTY	DESC
1	1	RECEPTACLE HOUSING ASSEMBLY
2	2	HOLDER HALVES
3	4	SELF TAPPING SCREWS

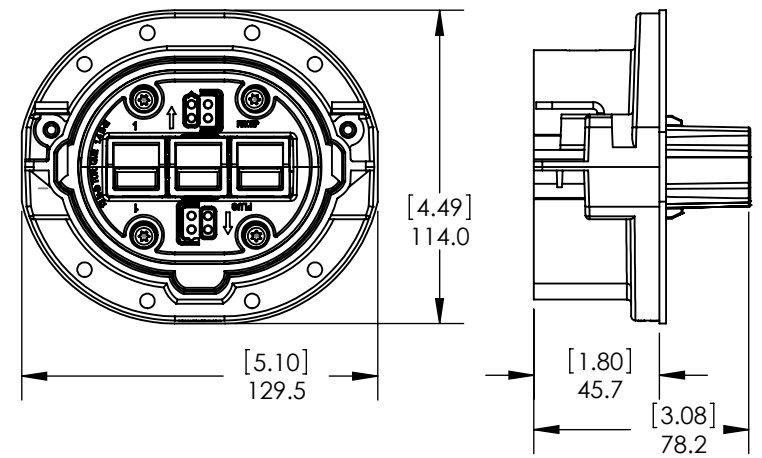

- NOTES:
 1. MATERIAL
 A. RECEPTACLE HOUSING AND HOLDER-PBT BLACK
 2. FOR USE WITH PP120 CONTACTS AND HOUSINGS (ORDERED SEPARATELY)
 3. HOLDER ACCEPTS UP TO FOUR POWERMOD™ PINS AND FOUR POWERMOD™ SOCKETS (ORDERED SEPARATELY)
 4. REFER TO ASSEMBLY INSTRUCTIONS 1S6555

DIMENSIONS ARE IN: MM(INCH)		APPROVALS		ANDERSON POWER PRODUCTS		
UNLESS OTHERWISE STATED		DRAWN	TWE	11/8/2010	TITLE HIGH POWER SPEC PAK™ PP120 PANEL MOUNT RECEPTACLE CONNECTOR KIT SK2-095H03	
TOLERANCES:		CHECKED	CMS	11/17/2010		
DECIMALS (INCH)	DECIMALS (MM)	ANGLES	MFG APPRV	CHB		11/22/2010
.XX ±.02	.X ±.5	±2°	QC APPRV	UPN		11/22/2010
SURFACE FINISH:		ENG APPRV	BD	11/22/2010		SIZE 0A
MATERIAL:		FINISH:		DWG NO.	REV.	
SEE NOTES				115028S1	0	
3rd ANGLE PROJECTION		-CAD GENERATED DRAWING- DO NOT MANUALLY UPDATE DO NOT SCALE		SCALE	SHEET	
				NONE	1 OF 2	
				CADFILE		
				03323		

REV.	DESCRIPTION	APPRV	DATE
REVISIONS			

THE INFORMATION CONTAINED IN THIS DRAWING IS THE SOLE PROPERTY OF ANDERSON POWER PRODUCTS. ANY REPRODUCTION IN PART OR WHOLE WITHOUT THE WRITTEN PERMISSION OF ANDERSON POWER PRODUCTS IS PROHIBITED.

Copyright 2010

ANDERSON POWER PRODUCTS RESERVES THE RIGHT TO ALTER PRODUCT TYPES, THEIR TECHNICAL DATA, DIMENSION, STYLE AND ACCESSORIES WITHOUT PRIOR NOTIFICATION.

APPROXIMATE OVERALL LENGTH RECEPTACLES AND PLUGS WITH GLANDS

**PANEL MT W/
PG-42 GLAND**

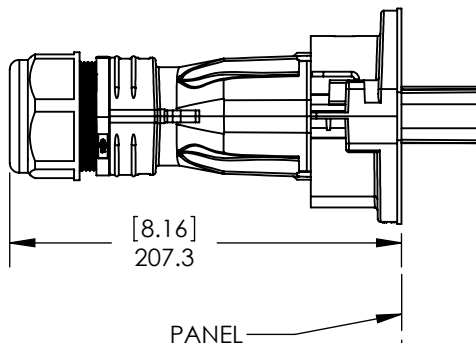

**PANEL MT W/
PG-36 GLAND**

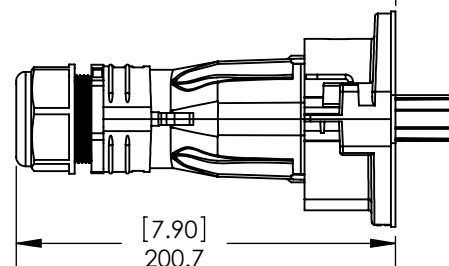

DIMENSIONS ARE IN:		MM(INCH)		<i>APPROVALS</i>		ANDERSON POWER PRODUCTS	
UNLESS OTHERWISE STATED				DRAWN	TWE	11/8/2010	TITLE HIGH POWER SPEC PAK™ PP120 PANEL MOUNT RECEPTACLE CONNECTOR KIT SK2-095H03
TOLERANCES:				CHECKED	CMS	11/17/2010	
DECIMALS (INCH)	DECIMALS (MM)	ANGLES		MFG APPRV	CHB	11/22/2010	
.XX ± .02	.X ± .5	±2°		QC APPRV	UPN	11/22/2010	
SURFACE FINISH:				ENG APPRV	BD	11/22/2010	
MACHINED		128 [3.2] ✓		SIZE	0A	DWG NO.	115028S1
MOLDED		64 [1.6] ✓		SCALE	NONE	CADFILE	03323
MATERIAL: SEE NOTES				-CAD GENERATED DRAWING- DO NOT MANUALLY UPDATE DO NOT SCALE		SHEET	
FINISH:						2 OF 2	
REV. 0							