

THE INFORMATION CONTAINED IN THIS DRAWING IS THE SOLE PROPERTY OF ANDERSON POWER PRODUCTS. ANY REPRODUCTION IN PART OR WHOLE WITHOUT THE WRITTEN PERMISSION OF ANDERSON POWER PRODUCTS IS PROHIBITED.

Copyright 2012

ANDERSON POWER PRODUCTS RESERVES THE RIGHT TO ALTER PRODUCT TYPES, THEIR TECHNICAL DATA, DIMENSION, STYLE AND ACCESSORIES WITHOUT PRIOR NOTIFICATION.

SEAL NUT

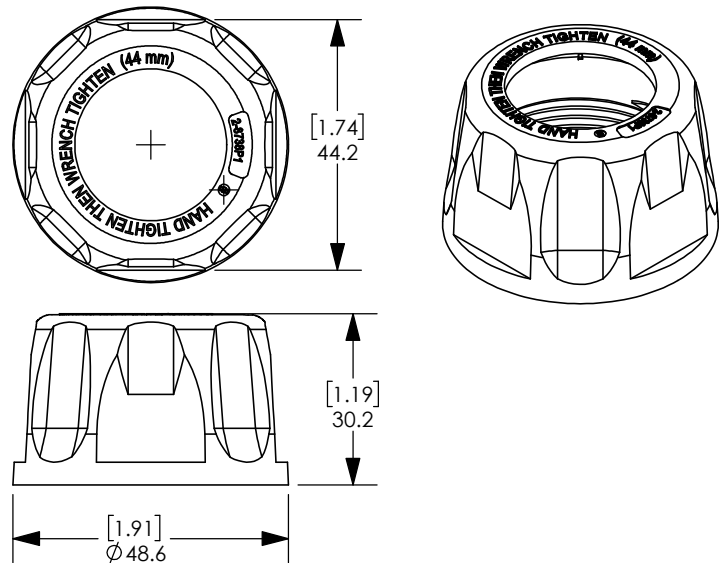

EXPLODED VIEW

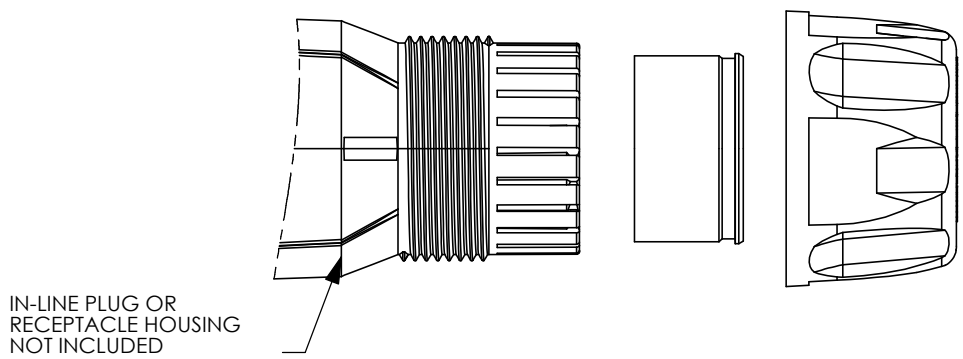

WIRE SEAL

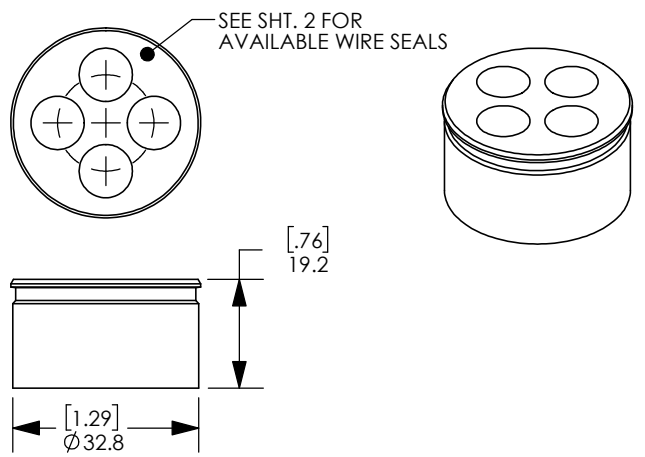

NOTES:

1. MATERIALS:
 - a. SEAL NUT- PBT/PC BLEND, UL94 V-0, BLACK
 - b. WIRE SEAL- EPDM RUBBER, BLACK
2. GLAND SEAL KITS INCLUDE ONE EACH SEAL NUT AND WIRE SEAL
3. REFER TO ASSEMBLY INSTRUCTIONS 1S6577 FOR IN-LINE PLUG AND 1S6575 FOR IN-LINE RECEPTACLE ASSEMBLY
4. FOR USE WITH MID POWER SPEC PAK® ONLY

REV.	DESCRIPTION	APPRV	DATE
2	ECN 2017-0005 - REMOVED PS3T40-5X FROM SHEET 2	CPD	2/17/2017
1	ECRN 15848: SEAL RANGE TABLE	CMS	7/30/2015
REVISIONS			

DIMENSIONS ARE IN:	MM [INCH]	APPROVALS		 ANDERSON POWER PRODUCTS
UNLESS OTHERWISE STATED		DRAWN		
TOLERANCES:		CMS	8/28/2012	
DECIMALS (INCH)	DECIMALS (MM)	ANGLES		
.XX ± .02	.X ± .5	±2°		TITLE
SURFACE FINISH:		CHECKED		MID POWER SPEC PAK® WIRE SEALS
MACHINED	3.2µ [128µin]	LLD	10/4/2012	
MOLDED	1.6µ [64µin]	MFG APPRV		
MATERIAL:		CHB	10/4/2012	QC APPRV
SEE NOTES		UFN	10/5/2012	
FINISH:		ENG APPRV		SIZE
N/A		CHB	10/4/2012	A
				DWG NO.
				115184S1
				REV.
				2
				SCALE
				NONE
				CADFILE
				03773
				SHEET
				1 OF 2

THE INFORMATION CONTAINED IN THIS DRAWING IS THE SOLE PROPERTY OF ANDERSON POWER PRODUCTS. ANY REPRODUCTION IN PART OR WHOLE WITHOUT THE WRITTEN PERMISSION OF ANDERSON POWER PRODUCTS IS PROHIBITED.

Copyright 2012

ANDERSON POWER PRODUCTS RESERVES THE RIGHT TO ALTER PRODUCT TYPES, THEIR TECHNICAL DATA, DIMENSION, STYLE AND ACCESSORIES WITHOUT PRIOR NOTIFICATION.

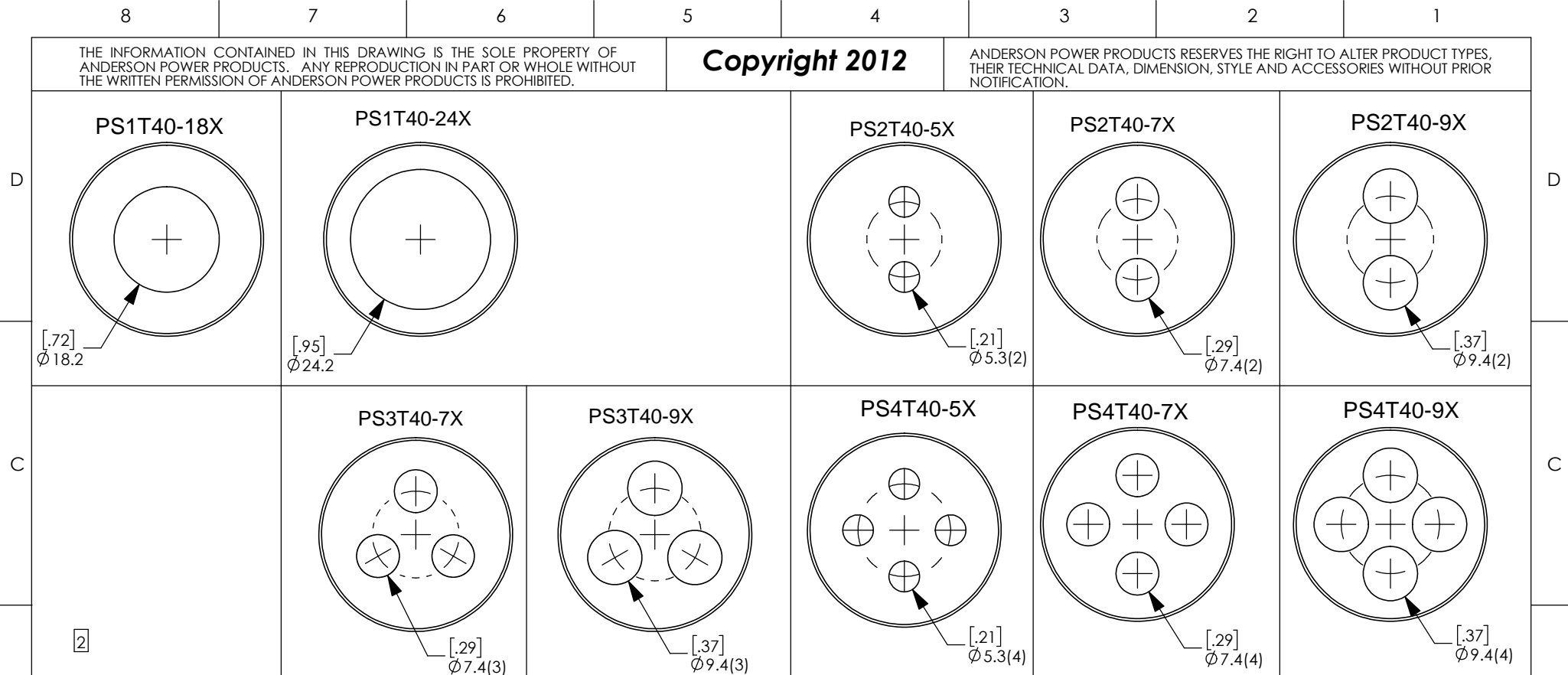

GLAND P/N	SPEC PAK CODE	WIRE SEALING RANGE			
		mm		INCHES	
		MIN	MAX	MIN	MAX
PS1T40-18X	PS01	13.0	18.0	0.51	0.71
PS1T40-24X	PS02	18.0	24.0	0.71	0.94
PS2T40-5X	PM21	3.8	5.0	0.15	0.20
PS2T40-7X	PM22	6.0	7.2	0.24	0.28
PS2T40-9X	PM23	7.0	9.0	0.28	0.35
PS3T40-7X	PM32	6.0	7.2	0.24	0.28
PS3T40-9X	PM33	7.0	9.0	0.28	0.35
PS4T40-5X	PM41	3.8	5.0	0.15	0.20
PS4T40-7X	PM42	6.0	7.2	0.24	0.28
PS4T40-9X	PM43	7.0	9.0	0.28	0.35

DIMENSIONS ARE IN:	MM [INCH]	APPROVALS		 ANDERSON POWER PRODUCTS TITLE MID POWER SPEC PAK® WIRE SEALS
UNLESS OTHERWISE STATED		DRAWN	8/28/2012	
TOLERANCES:		CHECKED	10/4/2012	
DECIMALS (INCH)	DECIMALS (MM)	MFG APPRV	10/4/2012	
.XX ±.02	.X ±.5	QC APPRV	10/5/2012	
SURFACE FINISH:		ENG APPRV	10/4/2012	
MACHINED 3.2µ [128µin] ✓		SIZE	A	
MOLDED 1.6µ [64µin] ✓		DWG NO.	115184S1	
MATERIAL: SEE NOTES		REV.	2	
FINISH: N/A		SCALE	NONE	
 3rd ANGLE PROJECTION		CADFILE	03773	
-CAD GENERATED DRAWING- DO NOT MANUALLY UPDATE DO NOT SCALE		SHEET	2 OF 2	