

User Instructions for PM1003GX- Powermod® Crimp Contact Insertion Inspection Tool

The 1003GX Inspection tool is used on both the male and female crimp contacts to confirm that the contact is securely latched into the housing. Do not use this tool on PCB contacts.

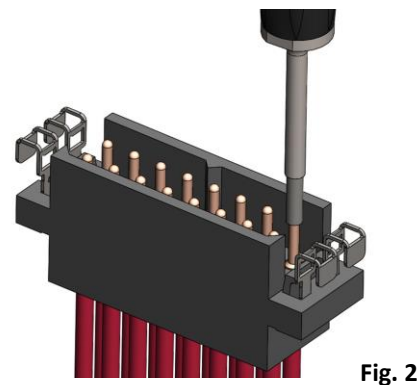

- A. Line the tool up with the contact to be tested.
- B. When testing sockets, place the tool on the top edge of the socket contact (Fig. 1)
- C. When testing pins, place the tool over the top radius of the pin contacts (Fig. 2)

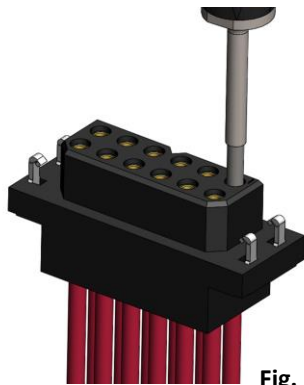

- D. Firmly grasp the handle and press down on the tool rapidly. The center plunger will recede into the outer tube under the compressive force.
- E. Stop applying force when the center plunger has receded back to the outer tube (Fig. 3). The total travel of the center plunger is 7.5mm [.30 inches]

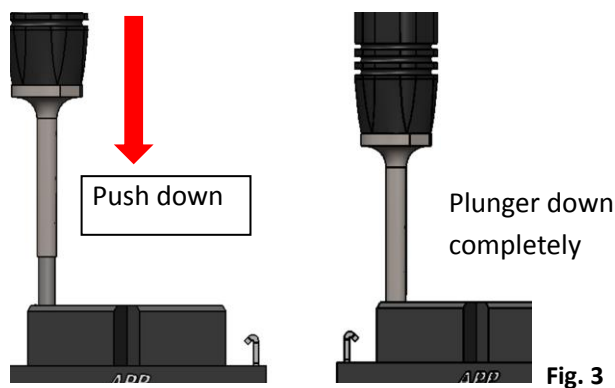

F. Pull the tool away and check the position of the contact. If the contact has not pushed back then the contact is securely latched into position.

G. Repeat with the remaining contacts.

H. Re-insert any contact that was pushed back with the inspection tool, making sure to fully snap the contact into place. Re-check with the inspection tool to confirm that the contact is securely latched.



Your Best Connection

An **IDEAL** Company

Anderson Power Products®
13 Pratts Junction Road
Sterling, MA 01564-2305 USA
Tel: 978-422-3600
Fax: 978-422-0128
www.andersonpower.com
ISO 9001:2008 Certified

The PM1003GX inspection tool can be used in any product that utilizes Powermod® crimp contacts. This includes the PowerMod connectors, Spec Pak® family of products with auxiliary positions (High Power, Mid Power), as well as the Mini Spec Pak® family, the SB® Smart connector and the 1x4 Auxiliary housing for use in the SBE/SBX family. Below is shown the inspection tool being used on the High Power Spec Pak®.

