

THE INFORMATION CONTAINED IN THIS DRAWING IS THE SOLE PROPERTY OF ANDERSON POWER PRODUCTS. ANY REPRODUCTION IN PART OR WHOLE WITHOUT THE WRITTEN PERMISSION OF ANDERSON POWER PRODUCTS IS PROHIBITED.

Copyright 2014

ANDERSON POWER PRODUCTS RESERVES THE RIGHT TO ALTER PRODUCT TYPES, THEIR TECHNICAL DATA, DIMENSION, STYLE AND ACCESSORIES WITHOUT PRIOR NOTIFICATION.

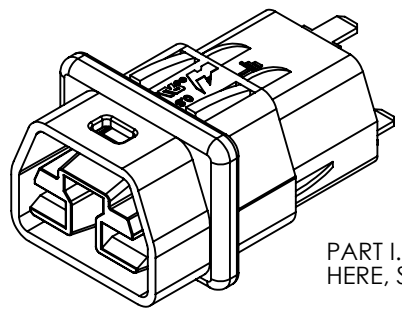

PART I.D. LOCATED HERE, SEE TABLE

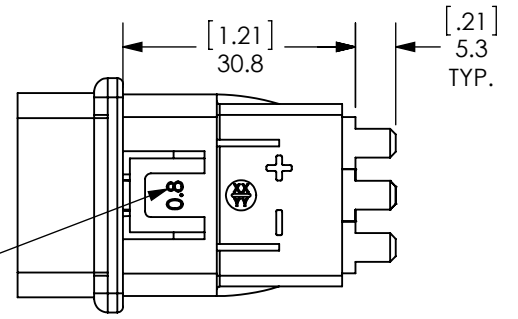
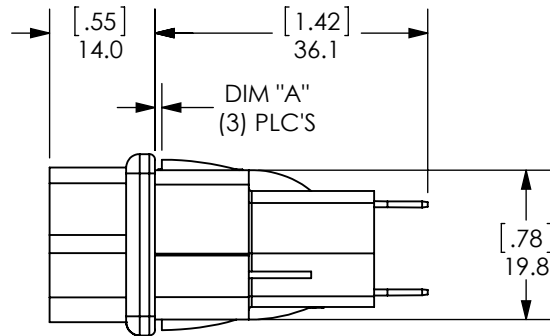
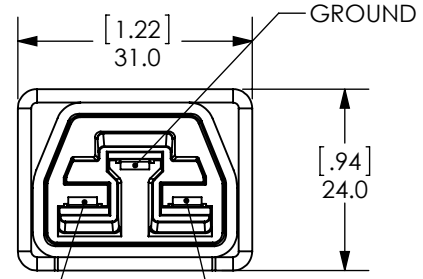
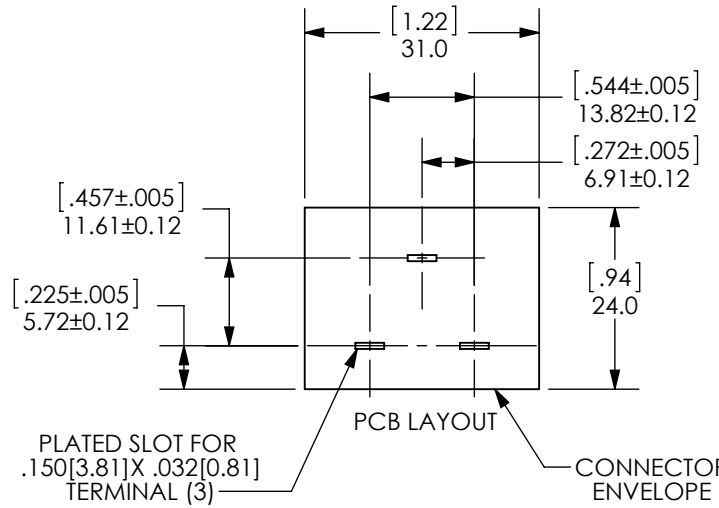
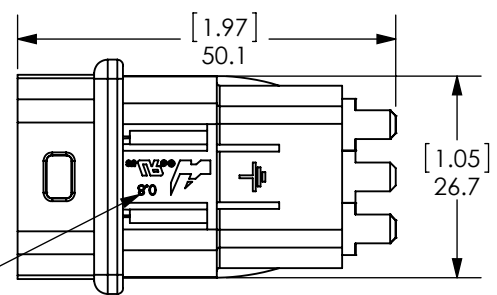

PART I.D. LOCATED HERE, SEE TABLE

NOTES:

- FOR USE WITH IEC320 C14 PANEL CUT-OUTS.
- *INDICATES NON STOCK ITEM. CONTACT FACTORY FOR AVAILABILITY.
- HOUSING MATERIAL: POLYCARBONATE
- CONTACT MATERIAL: COPPER ALLOY WITH SILVER PLATE

CATALOG NUMBER	PANEL THICKNESS		DIM "A" ^{+0.006[0.15]} _{-0.004[0.10]}		PART ID
	INCH	MM	INCH	MM	
2005V1	.031	0.80	.036	0.91	"0.8"
2005V2*	.047	1.20	.056	1.42	"1.2"
2005V3	.039	1.00	.044	1.13	"1.0"
2005V4	.063	1.60	.072	1.82	"1.6"
2005V5*	.079	2.00	.088	2.24	"2.0"
2005V6*	.098	2.50	.107	2.72	"2.5"

DIMENSIONS ARE IN:	MM [INCH]
UNLESS OTHERWISE STATED	
TOLERANCES:	
DECIMALS (INCH)	DECIMALS (MM) ANGLES
.XX ± .02	.X ± .5 ±2°
SURFACE FINISH:	
MACHINED	3.2µ [128µin] ✓
MOLDED	1.6µ [64µin] ✓
MATERIAL: SEE NOTES	
FINISH: N/A	

APPROVALS	
DRAWN	MC 5/28/2014
CHECKED	CLY 5/29/2014
MFG APPR	LLD 5/29/2014
QC APPR	HN 5/29/2014
ENG APPR	BD 5/29/2014

ANDERSON POWER PRODUCTS

TITLE: SAF-D-GRID® 2005 V SERIES PCB PANEL MOUNT ASSEMBLY

SIZE: A DWG NO. 115371S3 REV. 2

REV.	DESCRIPTION	APPRV	DATE
2	ECRN-15808 MOVED SLOTS ON PCB	AHR	4/14/2015
1	ECRN-15758 MOVED SLOTS ON PCB	AHR	1/26/15
REVISIONS			

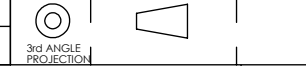

-CAD GENERATED DRAWING-
DO NOT MANUALLY UPDATE
DO NOT SCALE

SCALE	CADFILE	SHEET
NONE	04303	1 OF 1