

THE INFORMATION CONTAINED IN THIS DRAWING IS THE SOLE PROPERTY OF ANDERSON POWER PRODUCTS. ANY REPRODUCTION IN PART OR WHOLE WITHOUT THE WRITTEN PERMISSION OF ANDERSON POWER PRODUCTS IS PROHIBITED.

Copyright 2009

ANDERSON POWER PRODUCTS RESERVES THE RIGHT TO ALTER PRODUCT TYPES, THEIR TECHNICAL DATA, DIMENSION, STYLE AND ACCESSORIES WITHOUT PRIOR NOTIFICATION.

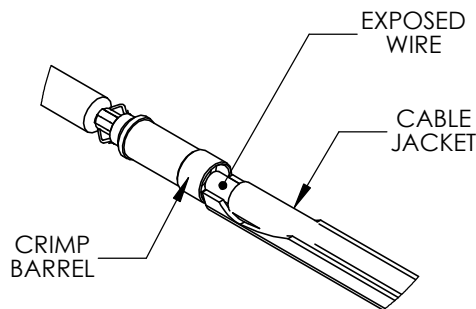
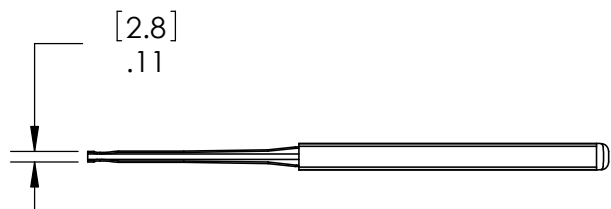
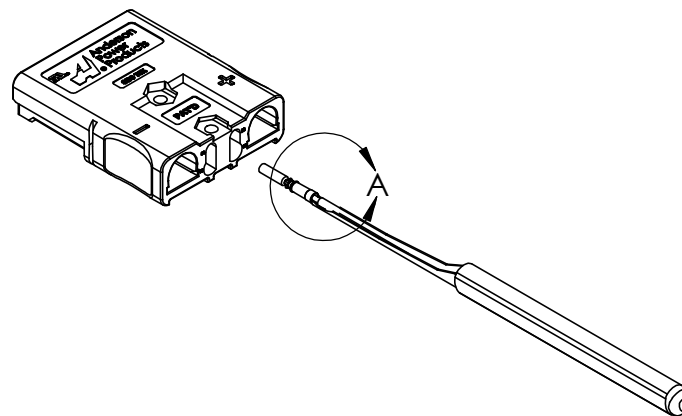
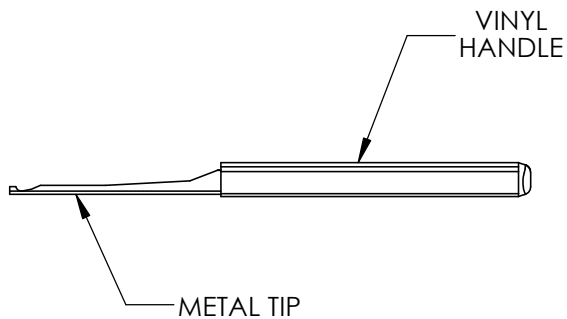

**DETAIL A**  
**SCALE 2 : 1**

INSERTION INSTRUCTIONS:

1. POSITION TOOL SUCH THAT THE CURVED TIP CRADLES EXPOSED WIRE BETWEEN CONTACT CRIMP BARREL AND CABLE JACKET.
2. GRIP VINYL HANDLE AND PUSH CONTACT FIRMLY INTO HOUSING. UNTIL IT SNAPS IN PLACE.
3. POSITION THE TOOL AT A SLIGHT UPWARDS ANGLE AND PULL BACK GENTLY, REMOVING THE TOOL FROM THE HOUSING.
4. CONFIRM THAT THE CONTACT HAS BEEN INSTALLED CORRECTLY BY TWISTING THE CABLE; THE CONTACT SHOULD ROTATE FREELY.

DIMENSIONS ARE IN: INCH[MM]		APPROVALS		ANDERSON POWER PRODUCTS		
UNLESS OTHERWISE STATED		DRAWN	AMS	10/29/09	TITLE SBS75X AUX. CONTACT INSERTION TOOL CAT. NO. 111038G3	
TOLERANCES:		CHECKED	DJD	10/29/09		
DECIMALS (INCH)	DECIMALS (MM)	ANGLES	MFG APP	CHB		10/29/09
.XX ±.02	.X ±.5	±2°	QC APP	UFN		10/29/09
SURFACE FINISH:		ENG APP	BD	10/29/09	SIZE	
MACHINED	128 [3.2]				A/A4	
MOLDED	64 [1.6]				DWG NO.	
MATERIAL:					111038S3	
FINISH:					REV.	
					0	
					SCALE	
					NONE	
					CADFILE	
					02965	
					SHEET	
					1 OF 1	

*	*****	***	*****
REV.	DESCRIPTION OF CHANGES	APPROVED	DATE
8			
7			
6			
5			



CAD GENERATED DRAWING  
DO NOT MANUALLY UPDATE  
DO NOT SCALE